

HTW

QUALITY COMFORT EVERYWHERE

Condensate p u m p s catalogue

AIR CONDITIONING



Index

Condensate pump HTW18BCMINI 4
Condensate pump HTW24BCDECO 6
Condensate pump HTW125BCEXT 8

ACCESORIES RANGE

Condensate pump

HTW18BCMINI

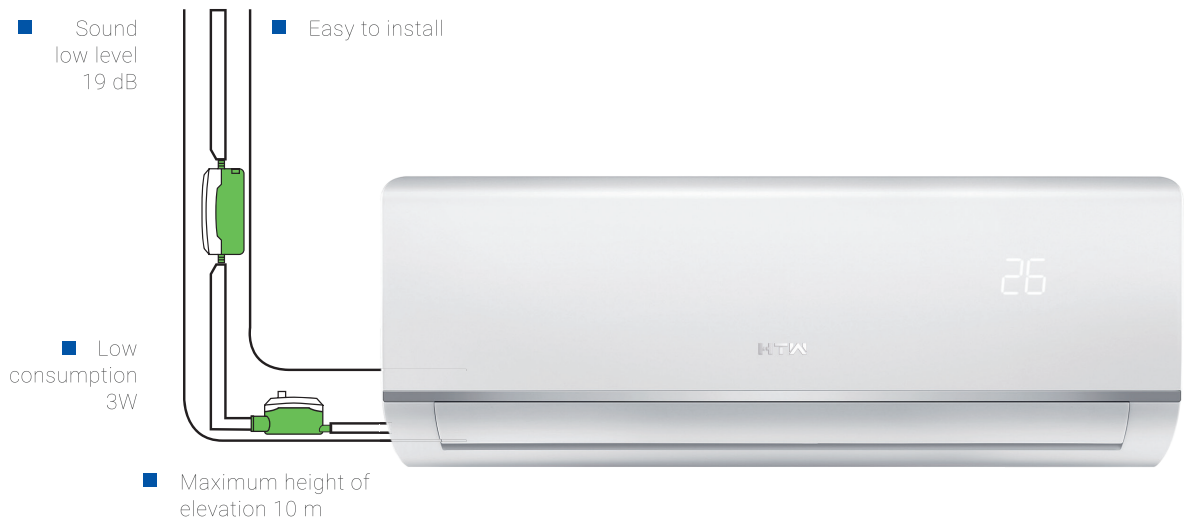

Lifting height 10 m

Condensate pumps for split up to 8 kW ideal for installation in the gutter.

It has a small tank that is easy to locate inside the gutter.

The kit includes: 35 cc tank with filter to retain possible impurities from the condensate, pump, transparent connection pipe and connection cable between pump and tank, power cable, cable ties to secure the connections of the discharge pipes and adhesive tape to hold the tank and prevent it from moving and disconnecting.

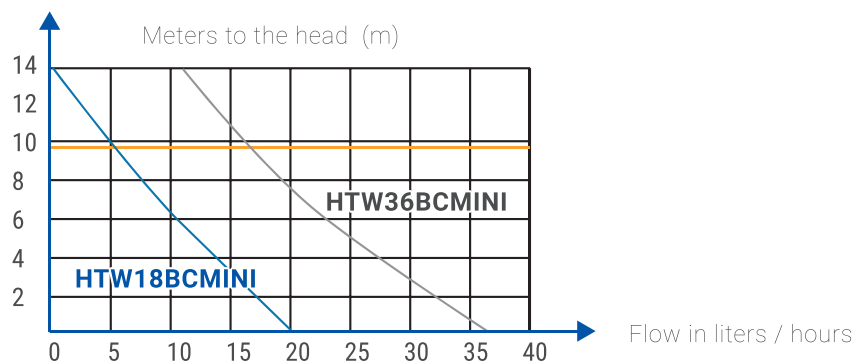

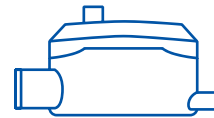

Data sheet

HTW18BCMINI

Maximum flow	L/h	18
Discharge height	m	10
Noise level	dB	19
Power supply	V	100 - 230V
Consumption	W	3
Tension	mA	50
Tank capacity	cc	35
Work temperature	°C	0 - 50
EAN code		8435483816329

Flow rates in L / h depending on the discharge height

	0m	2m	4m	6m	8m
HTW18BCMINI	18	12	8	7	6

Dimensions

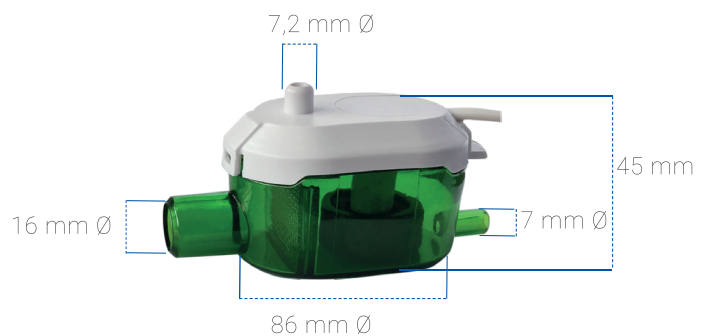
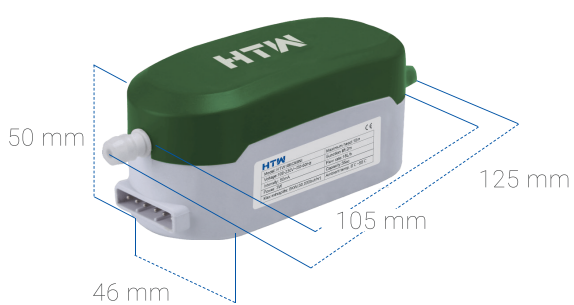

ACCESORIES RANGE

Condensate pump

- Sound low level 19 dB
- Low consumption 3W
- Easy to install
- Maximum height of elevation 10 m



Lifting height 10 m

Condensate pump for split up to 8 kW ideal to install under the split.

The pump has two possible drain tube connections, one on the top and one on the bottom side for greater installation flexibility.

The kit includes: bracket to hang and hold the pump, clamps for a correct fastening of the drain tube, power cable with 4 lines, 2 power lines and 2 communication lines.

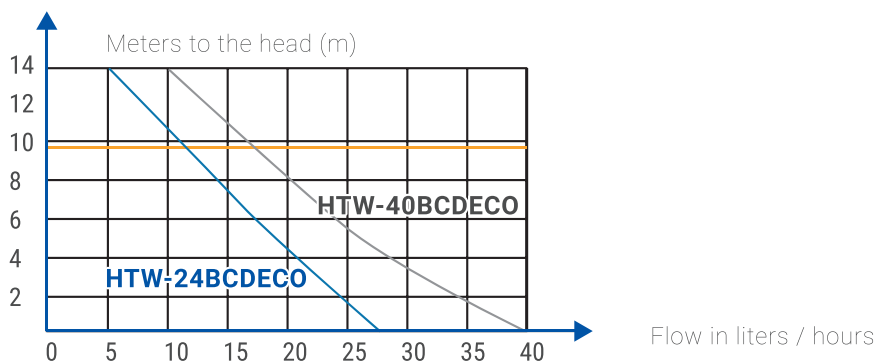



Data sheet

HTW24BCDECO

Maximum flow	L/h	24
Discharge height	m	10
Noise level	dB	19
Power supply	V	100 - 230V
Consumption	W	3
Tension	mA	50
Tank capacity	cc	200
Work temperature	°C	0 - 50
EAN code		8435483816336

Flow rates in L / h depending on the discharge height

	0m	2m	4m	6m	8m	10m
HTW24BCDECO	28	24	20	18	16	12

Measurements



ACCESORIES RANGE

Condensate pump

HTW125BCEXT

- Easy to install
- Deposit of great capacity
- To connect up to 5 units
- Maximum flow from 125 L / h



High flow and capacity condensate pump

The pump has five possible condensate inlet connections, four on the upper part and one on the lower side for greater installation flexibility.

The kit includes: pipe connection adapter, clamps for correct fastening of the drain tube, power cable with 5 lines, 3 power lines and 2 communication lines.

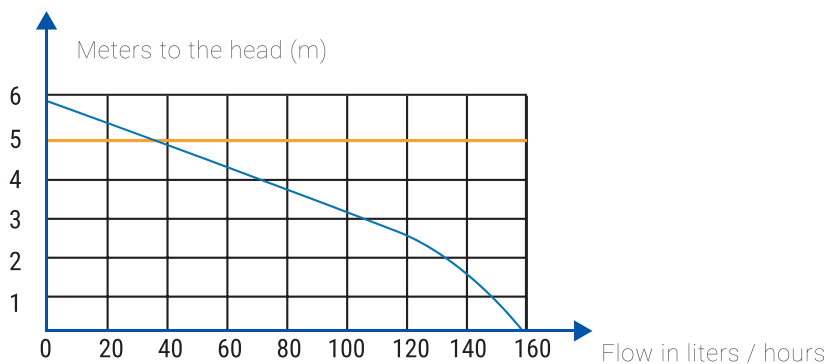

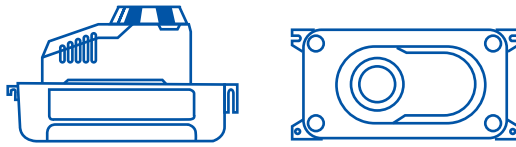

Data sheet

HTW125BCEXT

Maximum flow	L/h	125
Discharge height	m	4
Noise level	dB	19
Power supply	V	230V
Consumption	W	3
Tension	mA	-
Tank capacity	cc	1,8
Work temperature	°C	0 - 50
EAN code		8435483816343

Flow rates in L / h depending on the discharge height

	0m	2m	4m	6m	8m
HTW125BCEXT	160	150	130	110	40

Measurements

